



TGL 12.250 4x2 BL CH



CABS

	CC: NARROW, SHORT, NORMAL HEIGHT	TN: NARROW, LONG, NORMAL HEIGHT	DN: NARROW, EXTRA LONG, NORMAL HEIGHT
EXTERNAL LENGTH	1,620mm	2,280mm	2,790mm
EXTERNAL WIDTH	2,240mm	2,240mm	2,240mm
INTERIOR LENGTH	1,550mm	2,145mm	2,650mm
INTERIOR WIDTH	2,070mm	2,070mm	2,070mm
ENGINE TUNNEL HEIGHT	260/140mm	260mm	260mm
STANDING HEIGHT ON THE ENGINE TUNNEL	1,280mm	1,410mm	1,385mm
SEATS QUANTITY	2 (option for 3)	2	6 (option for 7)
STANDING HEIGHT IN FRONT OF THE CO-DRIVER'S SEAT	1,585mm	1,690mm	1,645/ 1,620mm
BUNK QUANTITY	-	1	-
BUNK WIDTH	-	800mm	-
BUNK LENGTH	-	1,960mm	-



CAB EXTERIOR

	CC	TN	DN
CAB PAINT RAL 9016	✓	✓	✓
BUMPER PAINT - TEXTURED COATING	-	-	-
CABIN TILT MECHANISM - MANUAL	✓	✓	✓
ROOF SPOILER	✓	✓	-
TILTING ROOF MECHANICAL	✓	✓	✓
SUNVISOR	✓	✓	✓
CENTRAL LOCKING WITH REMOTE CONTROL	✓	✓	✓
WIPER ACTIVATION, MANUAL	✓	✓	✓
FRONT HEADLIGHTS, H7	✓	✓	✓
DAYTIME DRIVING LIGHTS, LED	✓	✓	✓
DRIVING LIGHT CONTROL, MANUAL	✓	✓	✓
COMPRESSED AIR HORNS	-	✓	✓
EXTERIOR REAR VIEW MIRROR, ELECTRIC, MAIN AND SPOTTER	✓	✓	✓
KERB MIRROR LEFT, ELECTRIC	✓	✓	✓
FRONT MIRROR, MECHANICAL	✓	✓	✓

TGL 12.250 4×2 BL CH



CAB INTERIOR

	CC	TN	DN
MULTI-FUNCTION STEERING WHEEL, ADJUSTABLE HEIGHT AND ANGLE	✓	✓	✓
STEERING WHEEL, WITH PARKING POSITION	✓	✓	✓
STEERING LOCK, WITH ELECTRONIC IMMOBILISER	✓	✓	✓
COMFORT DRIVER'S SEAT, AIR-SPRUNG, WITH LUMBAR SUPPORT AND SHOULDER ADJUSTMENT	✓	✓	✓
DRIVER'S SEAT HEATING	✓	✓	✓
DRIVER'S SEAT ARM RESTS	✓	✓	✓
CO-DRIVER'S SEAT, NOT SPRUNG, LENGTH, HEIGHT AND BACKREST ADJUSTMENT	✓	✓	✓
CO-DRIVER'S SEAT ARM RESTS	✓	✓	-
REAR BENCH SEAT FOR 4 PERSONS	-	-	✓
AIR-CONDITIONING SYSTEM, MANUAL	✓	-	✓
AIR-CONDITIONING, CLIMATRONIC	-	✓	-
MMT INFOTAINMENT SYSTEM, ADVANCED MID	✓	✓	✓
MAN SOUND SYSTEM	✓	✓	✓
SMARTPHONE INTEGRATION	✓	✓	✓
AUSTRALIA NAVIGATION MAP	✓	✓	✓
PREPARATION FOR REAR-VIEW CAMERA, 2 UNITS, ONE CAMERA LINKED TO REVERSE GEAR	✓	✓	✓
EXTENSION FOR PREPARATION FOR REAR-VIEW CAMERA, CONNECTION BEHIND CAB	✓	✓	✓
ADJUSTABLE BUNK HEADSECTION	-	✓	-
110mm COLD FOAM MATTRESS	-	✓	-
UNDERBUNK COOLBOX	-	✓	-

CC Cab

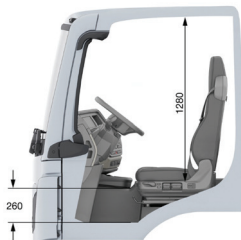

TN Cab

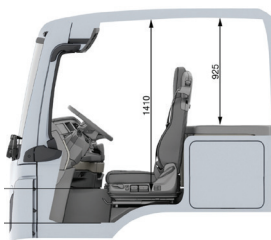

DN Cab

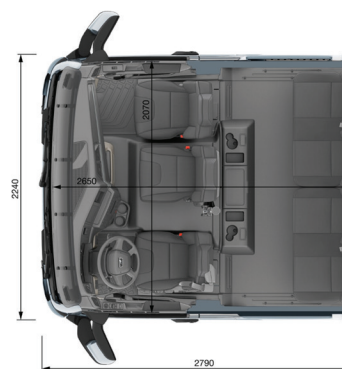
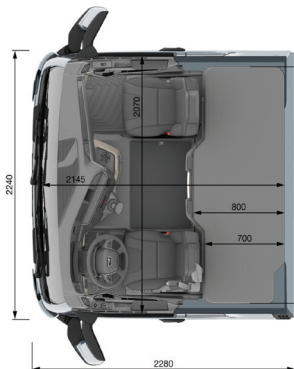
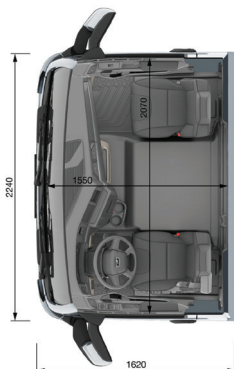
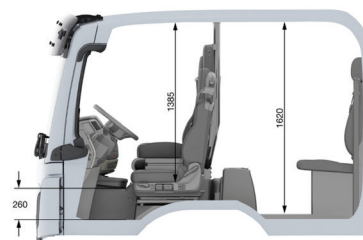

TGL 12.250 4×2 BL CH



ENGINE

250hp / 184kW – MAN D0836 LFL86	
NOMINAL OUTPUT	184kW (250hp) at 2,200rpm
MAX TORQUE	1,050Nm at 1,200–1,600rpm
CYLINDERS & ENGINE TYPE	Six-cylinder in-line engine
CAPACITY	6.9L
EMISSION NORM	Euro 5
EMISSION CONTROL SYSTEM	SCR technology – without EGR
ENGINE TURBO CHARGING	Single-stage turbo charger with direct air-air charge-air cooling
FUEL INJECTION	Electronically controlled common rail injection system



INTAKE/EXHAUST SYSTEM

	CC	TN	DN
AIR INTAKE LHS CABIN NO REAR PROTRUSION	-	✓	-
AIR INTAKE REAR OF CABIN RHS WITH REAR PROTURUSION	✓	-	✓
EXHAUST SILENCER RIGHT SIDE	✓	✓	✓
EXHAUST SILENCER COVER	✓	✓	✓



FRAME

	CC	TN	DN
FRAME PROFILE 220mm × 70mm × 6mm	✓	✓	✓
FRONT UNDERRIDE PROTECTION	✓	✓	✓
FINAL CROSS MEMBER WITH HOLE PATTERN 83 × 56mm/120 × 55mm	✓	✓	✓
SPARE WHEEL HOIST ON LEFT SIDE, BEHIND REAR AXLE	✓	✓	✓

TGL 12.250 4×2 BL CH



BRAKE SYSTEM

	CC	TN	DN
ANTI-LOCK BRAKING SYSTEM	✓	✓	✓
ELECTRONIC STABILITY PROGRAM	✓	✓	✓
ANTI-SLIP CONTROL	✓	✓	✓
MAN EASY START	✓	✓	✓
MAN HIGH PERFORMANCE ENGINE BRAKE	✓	✓	✓
ELECTRONIC BRAKING SYSTEM	✓	✓	✓
1 CYLINDER AIR COMPRESSOR 238 CCM	✓	✓	✓
PARK BRAKE CONTROL, IN INSTRUMENT PANEL	✓	✓	✓



DRIVETRAIN & CHASSIS EQUIPMENT

	CC	TN	DN
MAN TIPMATIC 1212 OD AMT GEARBOX	✓	✓	✓
MAN EFFICIENTROLL GEARBOX FUNCTION	✓	✓	✓
MAN TIPMATIC EFFICIENCY DRIVING PROGRAM	✓	✓	✓
MAN IDLE SPEED DRIVING GEARBOX FUNCTION	✓	✓	✓
SINGLE-DISC CLUTCH, 395mm, DRY	✓	✓	✓
4.8t DROPPED FRONT AXLE	✓	✓	✓
4.7t 1 LEAF PARABOLIC FRONT SUSPENSION	✓	✓	✓
8.7t HYPOID REAR AXLE	✓	✓	✓
8.4t 2 BAG ECAS REAR SUSPENSION	✓	✓	✓
3.36 REAR AXLE RATIO	✓	✓	✓
PI FR:01 245/70R R17.5" FRONT TYRES	✓	✓	✓
PI TR:01 245/70R R17.5" RER TYRES	✓	✓	✓
2 × 180L STEEL FUELS MOUNTED RHS CHASSIS	✓	✓	✓
35L ADBLUE MOUNTED RHS CAHSSIS	✓	✓	-
27L ADBLUE MOUNTED RHS CAHSSIS	-	-	✓

TGL 12.250 4×2 BL CH



ELECTRICAL SYSTEM

	CC	TN	DN
BATTERY, 12V, 88AH, 2 UNITS, MAINTENANCE FREE	✓	✓	✓
2 BATTERIES, 12V, 150AH, STANDARD (SLI), MAINTENANCE FREE	-	✓	-
ALTERNATOR, BASIC	✓	✓	-
THREE-PHASE ALTERNATOR 28V, 120A, 3,360W, LONGLIFE ECO	-	-	✓
MAIN BATTERY SWITCH, MECHANICAL	✓	✓	✓
LOCKABLE BATTERY BOX, WITHOUT PADLOCK	✓	✓	✓
SAFETY CUT-OUT	✓	✓	✓



SAFETY FEATURES

	CC	TN	DN
LANE GUARD SYSTEM (LGS)	✓	✓	✓
ADVANCED EMERGENCY BRAKE ASSIST (EBA)	✓	✓	✓
ROAD SPEED LIMITER, ADJUSTABLE, LIMITER (ENGINE SPEED REGULATION)	✓	✓	✓
EMERGENCY BRAKING SIGNAL (ESS)	✓	✓	✓
CRUISE CONTROL	✓	✓	✓



GVM & GCM

	CC	TN	DN
GROSS VEHICLE MASS (GVM)	11,990kg	11,990kg	11,990kg
GROSS COMBINATION MASS (GCM)	24,000kg	24,000kg	24,000kg



FACTORY WARRANTY

	CC	TN	DN
1 YEAR ENTIRE VEHICLE COVERAGE	✓	✓	✓
4 YEAR / 300,000km DRIVELINE COVERAGE	✓	✓	✓

TGL 12.250 4x2 BL CH



CHASSIS DIMENSIONS AND WEIGHTS

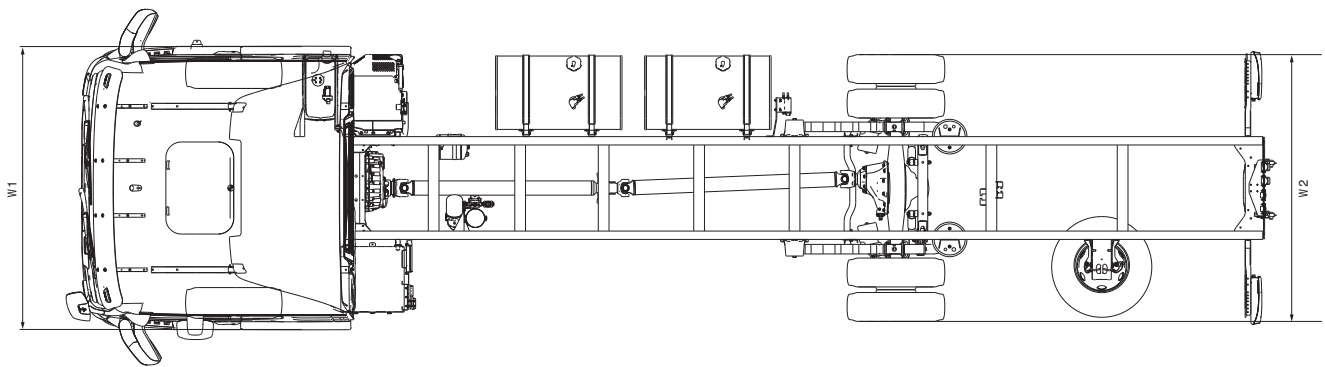
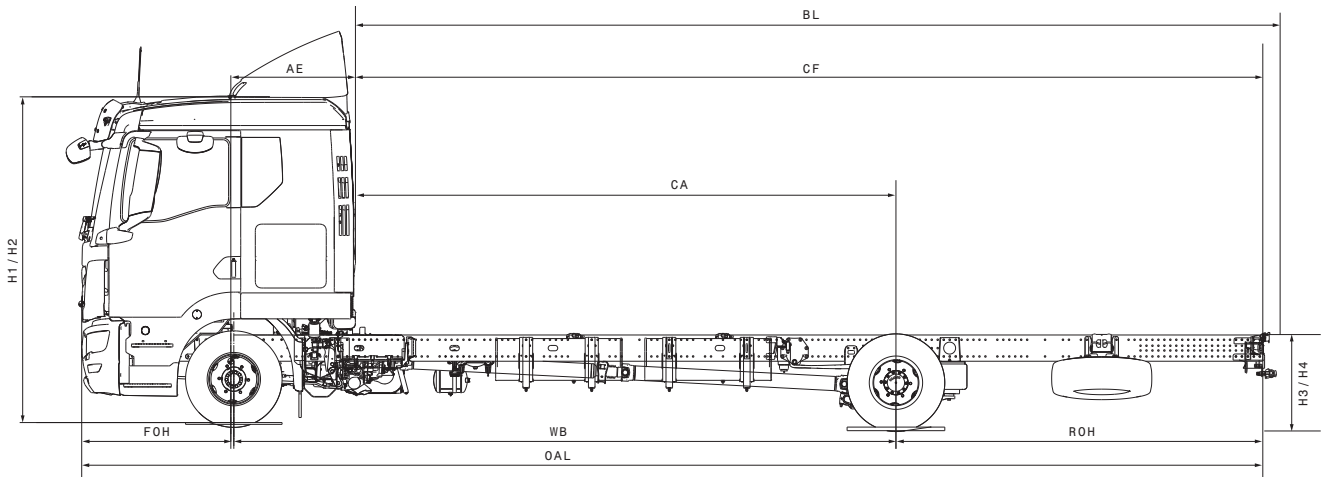

TGL 12.250 4×2 BL CH



CHASSIS DIMENSIONS AND WEIGHTS

WHEELBASE	CC CAB: WEIGHTS			TN CAB: WEIGHTS			DN CAB: WEIGHTS			TURNING	
	Front kg	Rear kg	Total	Front kg	Rear kg	Total	Front kg	Rear kg	Total	Kerb to Kerb	Wall to Wall
4,500mm	3,010	1,398	4,408	3,276	1,431	4,707	3,382	1,509	4,891	15.1	16.8
4,850mm	3,126	1,509	4,635	3,392	1,542	4,934	3,386	1,531	4,917	16.1	17.8
5,200mm	3,111	1,534	4,645	3,383	1,561	4,944	3,392	1,535	4,927	17.2	18.8
5,500mm	3,135	1,658	4,793	3,397	1,669	5,066	3,537	1,755	5,292	18.2	19.8

WHEELBASE	CC CABIN: CHASSIS DIMENSIONS						MAX (mm)	EMPTY (mm)	LOADED (mm)	EMPTY (mm)	LOADED (mm)		
	FOH	ROH	OAL	CA	CF	AE	BL	H1	H2	H3	H4	W1	W2
4,500mm	1,407	2,475	8,382	4,009	6,484	491	6,709	3,150	3,088	794	774	2,240	2,500
4,850mm	1,407	2,675	8,932	4,359	7,034	491	7,269	3,150	3,088	794	774	2,240	2,500
5,200mm	1,407	2,875	9,482	4,709	7,584	491	7,829	3,150	3,088	794	774	2,240	2,500
5,500mm	1,407	3,075	9,982	5,009	8,084	491	8,309	3,150	3,088	794	774	2,240	2,500

WHEELBASE	TN CABIN: CHASSIS DIMENSIONS						MAX (mm)	EMPTY (mm)	LOADED (mm)	EMPTY (mm)	LOADED (mm)		
	FOH	ROH	OAL	CA	CF	AE	BL	H1	H2	H3	H4	W1	W2
4,500mm	1,407	2,475	8,382	3,510	5,985	990	6,210	3,367	3,311	794	774	2,240	2,500
4,850mm	1,407	2,675	8,932	3,860	6,535	990	6,770	3,367	3,311	794	774	2,240	2,500
5,200mm	1,407	2,875	9,482	4,210	7,085	990	7,330	3,367	3,311	794	774	2,240	2,500
5,500mm	1,407	3,075	9,982	4,510	7,585	990	7,810	3,367	3,311	794	774	2,240	2,500

WHEELBASE	DN CABIN: CHASSIS DIMENSIONS						MAX (mm)	EMPTY (mm)	LOADED (mm)	EMPTY (mm)	LOADED (mm)		
	FOH	ROH	OAL	CA	CF	AE	BL	H1	H2	H3	H4	W1	W2
4,500mm	1,407	2,475	8,382	2,771	5,246	1,729	5,471	2,816	2,761	794	774	2,240	2,500
4,850mm	1,407	2,675	8,932	3,121	5,796	1,729	6,031	2,816	2,761	794	774	2,240	2,500
5,200mm	1,407	2,875	9,482	3,471	6,346	1,729	6,591	2,816	2,761	794	774	2,240	2,500
5,500mm	1,407	3,075	9,982	3,771	6,846	1,729	7,071	2,816	2,761	794	774	2,240	2,500

