



TGX 26.580-640 6x4 BL SA



CABS

	GN: WIDE, LONG, STANDARD HEIGHT	GM: WIDE, LONG, MEDIUM HEIGHT	GX: WIDE, LONG, EXTRA HEIGHT
EXTERNAL LENGTH	2,280mm	2,280mm	2,280mm
EXTERNAL WIDTH	2,440mm	2,440mm	2,440mm
INTERIOR LENGTH	2,145mm	2,145mm	2,145mm
INTERIOR WIDTH	2,270mm	2,270mm	2,270mm
ENGINE TUNNEL HEIGHT	120mm	120mm	120mm
STANDING HEIGHT ON THE ENGINE TUNNEL	1,580mm	1,860mm	2,070mm
SEATS QUANTITY	2	2	2
STANDING HEIGHT IN FRONT OF THE CO-DRIVER'S SEAT	1,660mm	1,940mm	2,150mm
BUNK QUANTITY	1	1	1
BUNK WIDTH	800mm	800mm	800mm
BUNK LENGTH	2,000mm	2,000mm	2,000mm



CAB EXTERIOR

	GN	GM	GX
CAB PAINT RAL 9016 - TRAFFIC WHITE	✓	✓	✓
BUMPER PAINT - RAL 9016 - TRAFFIC WHITE	✓	✓	✓
CABIN TILT MECHANISM - ELECTRIC	✓	✓	✓
ROOF SPOILER	✓	✓	✓
ELECTRIC GLASS SLIDING ROOF	✓	✓	✓
SUNVISOR	✓	✓	✓
WIPER ACTIVATION, AUTOMATIC	✓	✓	✓
FRONT HEADLIGHTS, LED	✓	✓	✓
DAYTIME DRIVING LIGHTS, LED	✓	✓	✓
FOG LIGHTS, LED	✓	✓	✓
CORNERING LIGHT, LED	✓	✓	✓
DRIVING LIGHT CONTROL, AUTOMATIC	✓	✓	✓
COMPRESSED AIR HORNS	✓	✓	✓
EXTERIOR REAR VIEW MIRROR, ELECTRIC, MAIN AND SPOTTER	✓	✓	✓
KERB MIRROR LEFT, ELECTRIC	✓	✓	✓
FRONT MIRROR, MECHANICAL	✓	✓	✓

TGX 26.580-640 6×4 BL SA



CAB INTERIOR

	GN	GM	GX
MULTI-FUNCTION STEERING WHEEL, ADJUSTABLE HEIGHT AND ANGLE	✓	✓	✓
STEERING WHEEL, WITH PARKING POSITION	✓	✓	✓
STEERING LOCK, WITH ELECTRONIC IMMOBILISER	✓	✓	✓
COMFORT DRIVER'S SEAT, AIR-SPRUNG, WITH LUMBAR SUPPORT AND SHOULDER ADJUSTMENT	✓	✓	✓
DRIVER'S SEAT HEATING	✓	✓	✓
DRIVER'S SEAT ARM RESTS	✓	✓	✓
VARIO CO-DRIVER'S SEAT, ROTATING, STATIC	✓	✓	✓
CO-DRIVER'S SEAT ARM RESTS	✓	✓	✓
AIR-CONDITIONING SYSTEM, CLIMATRONIC	✓	✓	✓
MMT INFOTAINMENT SYSTEM, ADVANCED HIGH	✓	✓	✓
MAN SOUND SYSTEM	✓	✓	✓
SMARTPHONE INTEGRATION	✓	✓	✓
AUSTRALIA NAVIGATION MAP	✓	✓	✓
PREPARATION FOR REAR-VIEW CAMERA, 2 UNITS, ONE CAMERA LINKED TO REVERSE GEAR	✓	✓	✓
REAR WALL STORAGE IN PLACE OF UPPER BUNK	-	-	✓
ADJUSTABLE BUNK HEADSECTION	✓	✓	✓
160mm INNER SPRING MATTRESS	✓	✓	✓
UNDERBUNK COOLBOX	✓	✓	✓

GN Cab

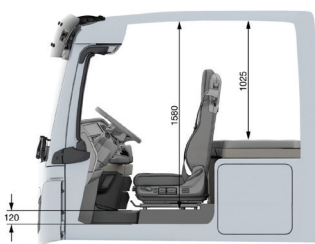

GM Cab

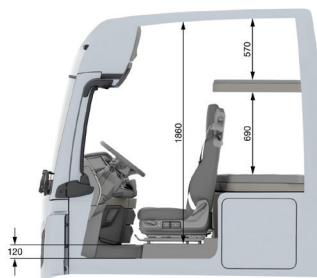

GX Cab

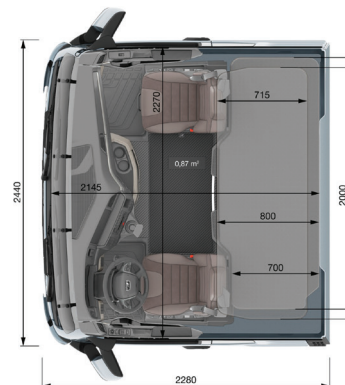
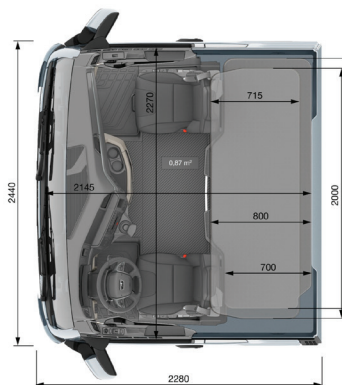
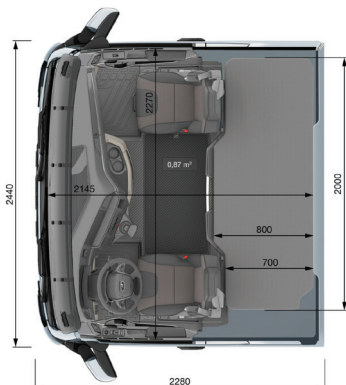
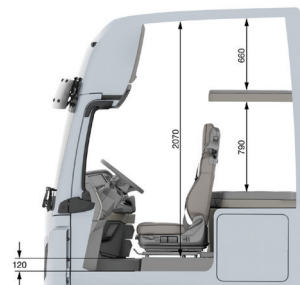

TGX 26.580-640 6×4 BL SA



ENGINE

	580	640
NOMINAL OUTPUT	427kW (580hp) at 1,800rpm	471kW (640hp) at 1,800rpm
MAX TORQUE	2,900Nm at 900–1,380rpm	3,000Nm at 900–1,380rpm
CYLINDERS & ENGINE TYPE	Six-cylinder in-line engine	Six-cylinder in-line engine
CAPACITY	15.2L	15.2L
EMISSION NORM	Euro 6e	Euro 6e
EMISSION CONTROL SYSTEM	Soft EGR,CRT & SCR	Soft EGR,CRT & SCR
ENGINE TURBO CHARGING	Two-stage turbo charging, with charge-air intercooling and charge-air cooling	Two-stage turbo charging, with charge-air intercooling and charge-air cooling
FUEL INJECTION	Electronically controlled common rail injection system	Electronically controlled common rail injection system



INTAKE/EXHAUST SYSTEM

	GN	GM	GX
AIR INTAKE LHS CABIN NO REAR PROTRUSION	✓	✓	✓
EXHAUST SILENCER RIGHT SIDE	✓	✓	✓
EXHAUST OUTLET, BOTTOM	✓	✓	✓
PRE-SEPARATOR FOR ENGINE AIR INTAKE	✓	✓	✓



FRAME

	GN	GM	GX
FRAME PROFILE 270mm × 85mm × 8mm	✓	✓	✓
FRONT UNDERRIDE PROTECTION	✓	✓	✓
FINAL CROSS MEMBER WITH HOLE PATTERN 160 × 100mm	✓	✓	✓

TGX 26.580-640 6×4 BL SA



BRAKE SYSTEM

	GN	GM	GX
ANTI-LOCK BRAKING SYSTEM	✓	✓	✓
ELECTRONIC STABILITY PROGRAM	✓	✓	✓
ANTI-SLIP CONTROL	✓	✓	✓
MAN EASY START	✓	✓	✓
MAN TURBO EVBEC HIGH PERFORMANCE ENGINE BRAKE	✓	✓	✓
ELECTRONIC BRAKING SYSTEM	✓	✓	✓
1 CYLINDER AIR COMPRESSOR 360 CCM	✓	✓	✓
PARK BRAKE CONTROL, FLOOR MOUNTED	✓	✓	✓
ANTI JACKKIFE BRAKE, FLOOR MOUNTED	✓	✓	✓



DRIVETRAIN & CHASSIS EQUIPMENT

	GN	GM	GX
MAN TIPMATIC 12 30 OD AMT GEARBOX	✓	✓	✓
MAN EFFICIENTROLL GEARBOX FUNCTION	✓	✓	✓
MAN TIPMATIC PERFORMANCE & EFFICIENCY DRIVING PROGRAM	✓	✓	✓
MAN IDLE SPEED DRIVING GEARBOX FUNCTION	✓	✓	✓
SINGLE-DISC CLUTCH, 430mm, DRY REINFORCED (LONGLIFE)	✓	✓	✓
9.2t DROPPED FRONT AXLE	✓	✓	✓
9.5t 3 LEAF PARABOLIC FRONT SUSPENSION	✓	✓	✓
TANDEM 13t HYPOID REAR AXLES	✓	✓	✓
TANDEM 11.5t 4 BAG ECAS REAR SUSPENSION	✓	✓	✓
3.36 REAR AXLE RATIO	✓	✓	✓
PI FR:01 295/80R22.5" FRONT TYRES	✓	✓	✓
PI TR:01 295/80R22.5" REAR TYRES	✓	✓	✓
1 × 620L FUEL /85L ADBLUE ALLOY COMBI TANK LEFT	✓	✓	✓
1 × 460L ALLOY FUELTANK RIGHT	✓	✓	✓
ALCOA DURA-BRIGHT ALLOY WHEELS	✓	✓	✓

TGX 26.580-640 6×4 BL SA



ELECTRICAL SYSTEM

	GN	GM	GX
2 BATTERIES, 12V, 230AH, MAINTENANCE FREE	✓	✓	✓
THREE-PHASE ALTERNATOR 28V, 120A, 3,360W, LIN	✓	✓	✓
MAIN BATTERY SWITCH, MECHANICAL	✓	✓	✓
SAFETY CUT-OUT	✓	✓	✓



SAFETY FEATURES

	GN	GM	GX
LANE GUARD ASSIST (LGA)	✓	✓	✓
COMFORT STEERING	✓	✓	✓
ADVANCED EMERGENCY BRAKE ASSIST (EBA)	✓	✓	✓
ROAD SPEED LIMITER, ADJUSTABLE, LIMITER (ENGINE SPEED REGULATION)	✓	✓	✓
EMERGENCY BRAKING SIGNAL (ESS)	✓	✓	✓
ADAPTIVE CRUISE CONTROL (ACC)	✓	✓	✓
DRIVER'S AIRBAG WITH SEATBELT PRE TENSIONER	✓	✓	✓



GVM & GCM

	GN	GM	GX
GROSS VEHICLE MASS (GVM)	26,000kg	26,000kg	26,000kg
GROSS COMBINATION MASS (GCM)	70,000kg	70,000kg	70,000kg
GROSS COMBINATION MASS (GCM) *OPTIONAL, RESTRICTIONS APPLY	90,000kg	90,000kg	90,000kg



FACTORY WARRANTY

	GN	GM	GX
1 YEAR ENTIRE VEHICLE COVERAGE	✓	✓	✓
5 YEAR 1,000,000km DRIVELINE COVERAGE - UP TO 70T GCM	✓	✓	✓
4 YEAR / 800,000KM DRIVELINE COVERAGE - 70T TO 90T GCM	✓	✓	✓
4 YEAR / 600,000KM DRIVELINE COVERAGE - > 90T GCM	✓	✓	✓

TGX 26.580-640 6×4 BL SA



CHASSIS DIMENSIONS AND WEIGHTS

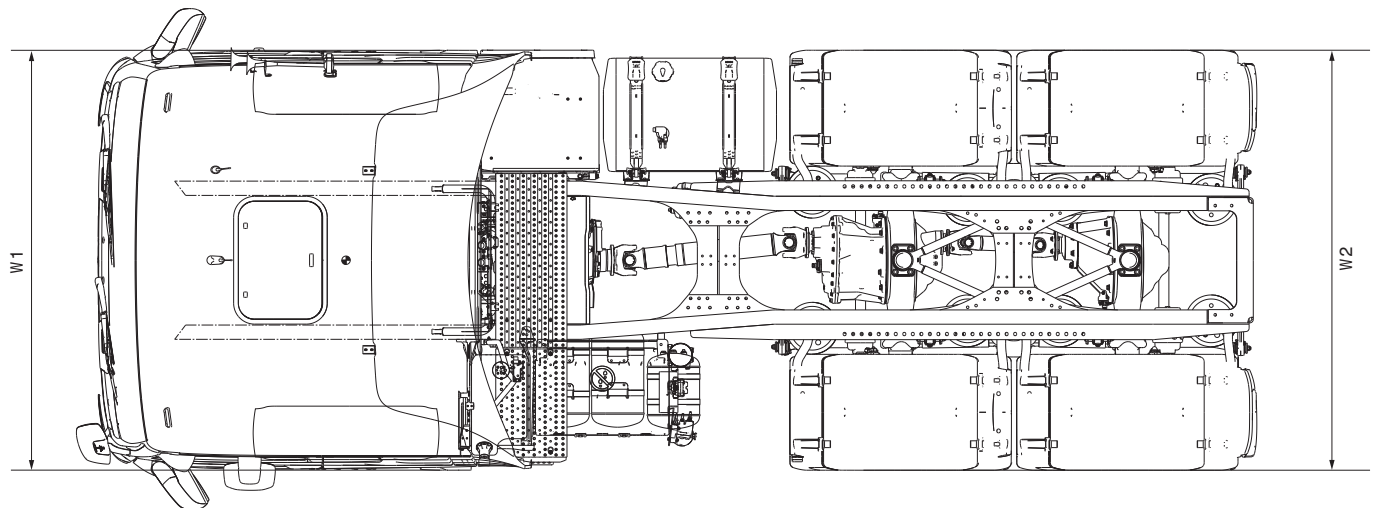
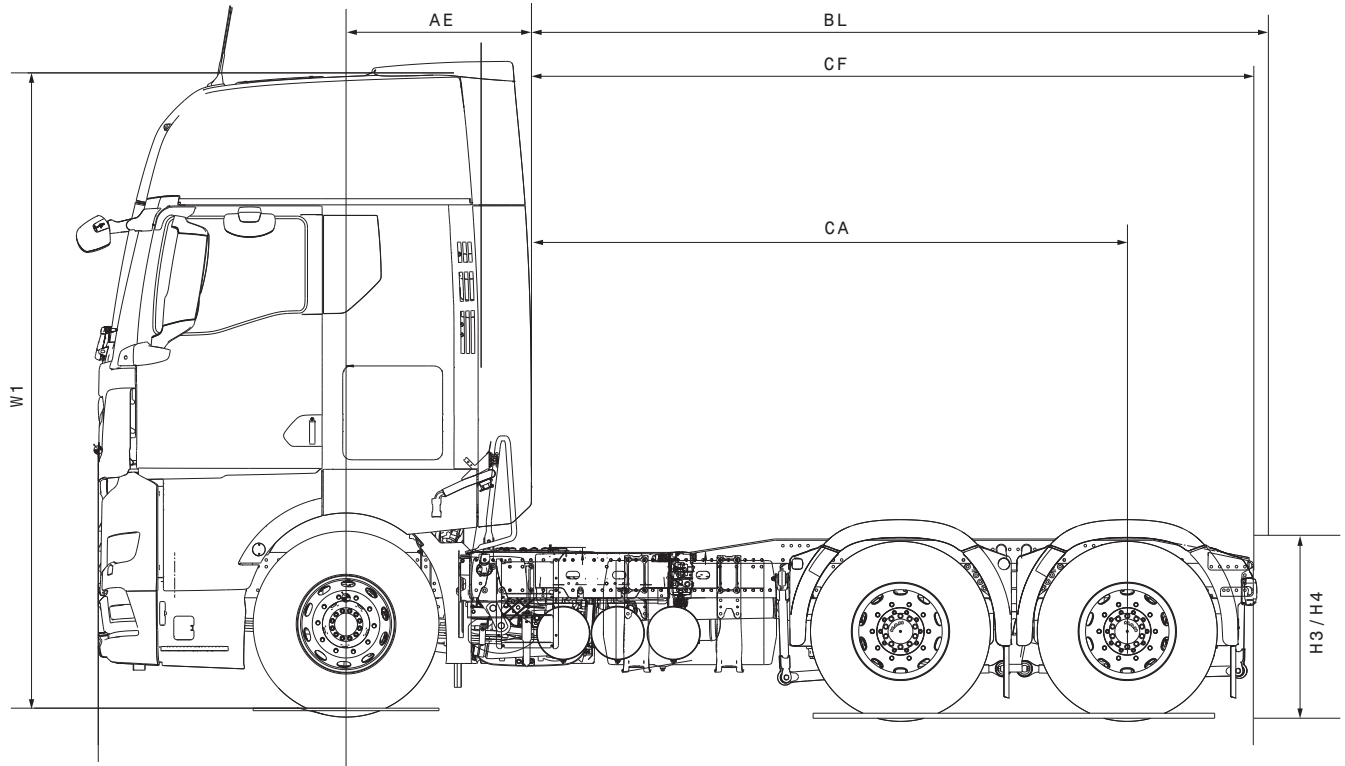

TGX 26.580-640 6×4 BL SA



CHASSIS DIMENSIONS AND WEIGHTS

WHEELBASE	GN CAB: WEIGHTS			GM CAB: WEIGHTS			GX CAB: WEIGHTS			TURNING	
	Front kg	Rear kg	Total	Front kg	Rear kg	Total	Front kg	Rear kg	Total	Kerb to Kerb	Wall to Wall
3,300mm	6,197	4,087	10,284	6,197	4,087	10,284	6,334	4,113	10,497	16.9	18.5

WHEELBASE	GN CABIN: CHASSIS DIMENSIONS							MAX (mm)	EMPTY (mm)	LOADED (mm)	EMPTY (mm)	LOADED (mm)	
	FOH	ROH	OAL	CA	CF	AE	BL	H1	H2	H3	H4	W1	W2
3,300mm	1,607	725	6,982	2,137	2,862	1,163	N/A	3,863	3,765	998	968	2,440	2,500

WHEELBASE	GM CABIN: CHASSIS DIMENSIONS							MAX (mm)	EMPTY (mm)	LOADED (mm)	EMPTY (mm)	LOADED (mm)	
	FOH	ROH	OAL	CA	CF	AE	BL	H1	H2	H3	H4	W1	W2
3,300mm	1,607	725	6,982	2,127	2,852	1,173	N/A	3,912	3,870	998	968	2,440	2,500

WHEELBASE	GX CABIN: CHASSIS DIMENSIONS							MAX (mm)	EMPTY (mm)	LOADED (mm)	EMPTY (mm)	LOADED (mm)	
	FOH	ROH	OAL	CA	CF	AE	BL	H1	H2	H3	H4	W1	W2
3,300mm	1,607	725	6,982	2,127	2,852	1,173	N/A	3,955	3,857	998	968	2,440	2,500

