



TGM 13.250-290 4×4 BL CH RV SPEC



CABS

	CC: NARROW, SHORT, NORMAL HEIGHT	TN: NARROW, LONG, NORMAL HEIGHT
EXTERNAL LENGTH	1,620mm	2,280mm
EXTERNAL WIDTH	2,240mm	2,240mm
INTERIOR LENGTH	1,550mm	2,145mm
INTERIOR WIDTH	2,070mm	2,070mm
ENGINE TUNNEL HEIGHT	260mm	260mm
STANDING HEIGHT ON THE ENGINE TUNNEL	1,280mm	1,410mm
SEATS QUANTITY	2 (optionally 3)	2
STANDING HEIGHT IN FRONT OF THE CO-DRIVER'S SEAT	1,585mm	1,690mm
BUNK QUANTITY	-	1
BUNK WIDTH	-	800mm
BUNK LENGTH	-	1,960mm



CAB EXTERIOR

	CC	TN
CAB PAINT RAL 9016	✓	✓
BUMPER PAINT - TEXTURED COATING	✓	✓
CABIN TILT MECHANISM - MANUAL	✓	✓
STEEL BUMPER	✓	✓
WIDE/FINE MESH HEADLIGHT PROTECTORS	✓	✓
TILTING ROOF MECHANICAL	✓	✓
SUNVISOR	✓	✓
CENTRAL LOCKING WITH REMOTE CONTROL	✓	✓
WIPER ACTIVATION, MANUAL	✓	✓
FRONT HEADLIGHTS, H7	✓	✓
DAYTIME DRIVING LIGHTS, LED	✓	✓
DRIVING LIGHT CONTROL, MANUAL	✓	✓
COMPRESSED AIR HORNS	✓	✓
EXTERIOR REAR VIEW MIRROR, ELECTRIC, MAIN AND SPOTTER	✓	✓
KERB MIRROR LEFT, ELECTRIC	✓	✓
FRONT MIRROR, MECHANICAL	✓	✓

TGM 13.250-290 4×4 BL CH RV SPEC



CAB INTERIOR

	CC	TN
MULTI-FUNCTION STEERING WHEEL, ADJUSTABLE HEIGHT AND ANGLE	✓	✓
STEERING WHEEL, WITH PARKING POSITION	✓	✓
COMFORT DRIVER'S SEAT, AIR-SPRUNG, WITH LUMBAR SUPPORT AND SHOULDER ADJUSTMENT	✓	✓
DRIVER'S SEAT HEATING	✓	✓
DRIVER'S SEAT ARM RESTS	✓	✓
COMFORT CO-DRIVER'S SEAT, AIR-SPRUNG, WITH LUMBAR SUPPORT AND SHOULDER ADJUSTMENT	✓	✓
CO-DRIVER'S SEAT ARM RESTS	✓	✓
REAR BENCH SEAT FOR 4 PERSONS	-	-
AIR-CONDITIONING SYSTEM, CLIMATRONIC	✓	✓
INSTRUMENTATION, BASIC	✓	✓
MAN NAVIGATION PROFESSIONAL MEDIA SYSTEM, 12.3 INCH	✓	✓
MAN SOUND SYSTEM	✓	✓
SMARTPHONE INTEGRATION	✓	✓
AUSTRALIA NAVIGATION	✓	✓
PREPARATION FOR REAR-VIEW CAMERA, 1 UNITS, ONE CAMERA LINKED TO REVERSE GEAR	✓	✓
EXTENSION FOR PREPARATION FOR REAR-VIEW CAMERA, CONNECTION BEHIND CAB	✓	✓
ADJUSTABLE BUNK HEADSECTION	-	✓
110mm COLD FOAM MATTRESS	-	✓
UNDERBUNK COOLBOX	-	✓

CC Cab

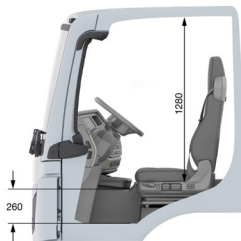

TN Cab

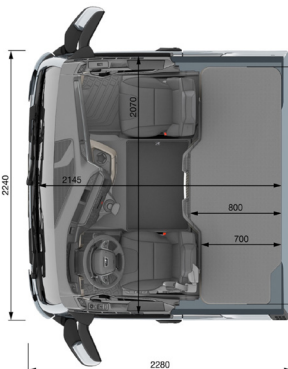
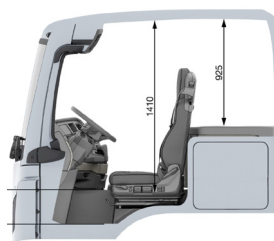

TGM 13.250-290 4×4 BL CH RV SPEC



ENGINE

	250hp / 184kW – MAN D0836 LFL86	290hp / 213kW – MAN D0836 LFL87
ENGINE SPECIFICATIONS		
NOMINAL OUTPUT	184kW (250hp) at 2,200rpm	213kW (290hp) at 2,200rpm
MAX TORQUE	1,050Nm at 1,200–1,600rpm	1,150Nm at 1,200–1,700rpm
CYLINDERS & ENGINE TYPE	Six-cylinder in-line engine	Six-cylinder in-line engine
CAPACITY	6.9L	6.9L
EMISSION NORM	Euro 5	Euro 5
EMISSION CONTROL SYSTEM	SCR technology – without EGR	SCR technology – without EGR
ENGINE TURBO CHARGING	Single-stage turbo charger with direct air-air charge-air cooling	Single-stage turbo charger with direct air-air charge-air cooling
FUEL INJECTION	Electronically controlled Common Rail injection system	Electronically controlled Common Rail injection system



INTAKE/EXHAUST SYSTEM

	CC	TN
AIR INTAKE LHS CABIN NO REAR PROTRUSION	-	✓
AIR INTAKE REAR OF CABIN RHS WITH REAR PROTURUSION	✓	-
EXHAUST SILENCER RIGHT SIDE	✓	✓
EXHAUST SILENCER COVER	✓	✓



FRAME

	CC	TN
FRAME PROFILE 220mm × 70mm × 7mm	✓	✓
FINAL CROSS MEMBER, WITH HOLE PATTERN 120 × 55 mm	✓	✓
SPARE WHEEL HOIST ON LEFT SIDE, IN FRONT OF REAR AXLE	✓	✓

TGM 13.250-290 4×4 BL CH RV SPEC



BRAKE SYSTEM

	CC	TN
ANTI-LOCK BRAKING SYSTEM (ABS), OFFROAD, WITH ADDITIONAL OFF-ROAD LOGIC	✓	✓
MAN EASY START	✓	✓
MAN HIGH PERFORMANCE ENGINE BRAKE	✓	✓
ELECTRONIC BRAKING SYSTEM	✓	✓
1 CYLINDER AIR COMPRESSOR 252 CCM	✓	✓
PARK BRAKE CONTROL, INSTRUMENT PANEL MOUNTED	✓	✓



DRIVETRAIN & CHASSIS EQUIPMENT

	CC	TN
MAN TIPMATIC 1212 OD AMT GEARBOX	✓	✓
MAN IDLE SPEED DRIVING GEARBOX FUNCTION	✓	✓
MAN TIPMATIC OFFROAD GEARBOX SHIFT STRATEGY	✓	✓
SINGLE-DISC CLUTCH, 395mm, DRY	✓	✓
TRANSFER CASE MAN G102 WITH ON-ROAD AND OFF-ROAD GEAR	✓	✓
TRANSFER CASE LOCK MANAGEMENT, ELECTRONIC (VSM)	✓	✓
FRONT AXLE TYPE, PERMANENT	✓	✓
6.3t STRAIGHT FRONT PLANETARY AXLE	✓	✓
6.3t 2 LEAF PARABOLIC FRONT SUSPENSION	✓	✓
7.8t STRAIGHT REAR PLANETARY AXLE	✓	✓
7.8t 4 BAG ECAS REAR CONSTRUCTION SUSPENSION	✓	✓
5.07 REAR AXLE RATIO	✓	✓
MICHELIN X WORKS HL Z 385/65 R22.5 FRONT TYRES	✓	✓
MICHELIN X WORKS HL Z 385/65 R22.5 REAR TYRES	✓	✓
1 × 300L STEEL FUELTANK MOUNTED RHS CHASSIS	✓	✓
65L ADBLUE TANK MOUNTED RHS CHASSIS	✓	✓
CONSOLE FOR AUXILIARY UNIT ON THE ENGINE	✓	✓

TGM 13.250-290 4×4 BL CH RV SPEC



ELECTRICAL SYSTEM

	CC	TN
BATTERY, 12 V, 175 AH, 2 UNITS, MAINTENANCE FREE	✓	✓
THREE-PHASE ALTERNATOR 28V, 120A, 3,360W, LONGLIFE ECO	✓	✓
MAIN BATTERY SWITCH, MECHANICAL	✓	✓
LOCKABLE BATTERY BOX, WITHOUT PADLOCK	✓	✓
SAFETY CUT-OUT	✓	✓



SAFETY FEATURES

	CC	TN
ROAD SPEED LIMITER, ADJUSTABLE, LIMITER (ENGINE SPEED REGULATION)	✓	✓
EMERGENCY BRAKING SIGNAL	✓	✓
CRUISE CONTROL	✓	✓



GVM & GCM

	CC	TN
GROSS VEHICLE MASS (GVM)	13,000kg	13,000kg
GROSS COMBINATION MASS (GCM)	28,000kg	28,000kg
GROSS COMBINATION MASS (GCM) *APPLICABLE WITH ENGAGEABLE TRANSFER CASE*	20,000kg	20,000kg



FACTORY WARRANTY

	CC	TN
1 YEAR ENTIRE VEHICLE COVERAGE	✓	✓
2 YEAR DRIVE LINE COVERAGE	✓	✓

TGM 13.250-290 4×4 BL CH RV SPEC



CHASSIS DIMENSIONS AND WEIGHTS

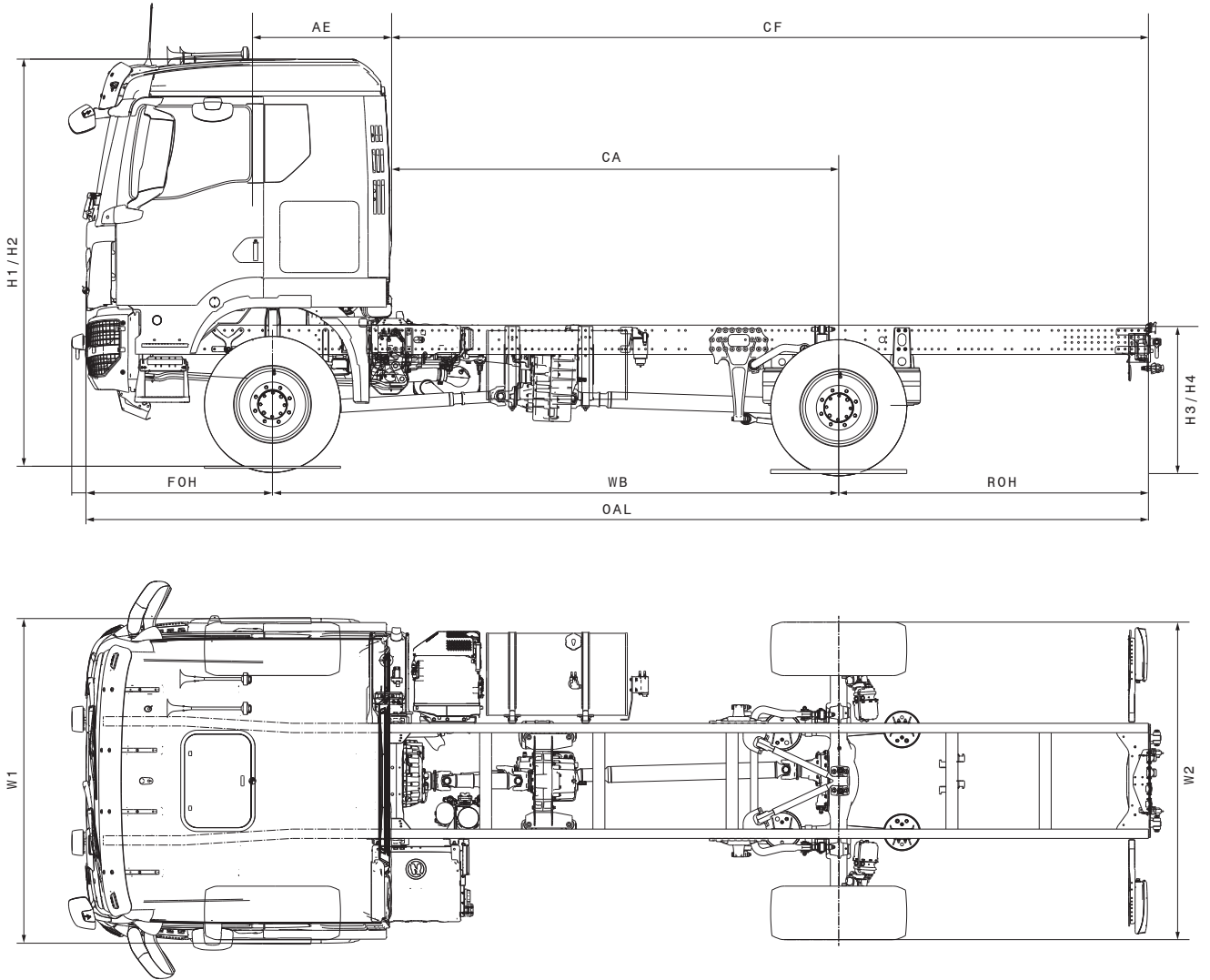

TGM 13.250-290 4×4 BL CH RV SPEC



CHASSIS DIMENSIONS AND WEIGHTS

	CC CAB: WEIGHTS			TN CAB: WEIGHTS			TURNING	
WHEELBASE	Front kg	Rear kg	Total	Front kg	Rear kg	Total	Kerb to Kerb	Wall to Wall
4,250mm	4,123	1,682	5,805	4,433	1,778	6,211	16.3	17.7

* reduction in fuel capacity required for DN Cabin

	CC CABIN: CHASSIS DIMENSIONS						EMPTY (mm)	LOADED (mm)	EMPTY (mm)	LOADED (mm)	WIDTH (mm)	
WHEELBASE	FOH	ROH	OAL	CA	CF	AE	H1	H2	H3	H4	W1	W2
4,250mm	1,450	2,325	8,107	3,809	6,134	441	3,130	3,130	1,159	1,129	2,240	2,500

	TN CABIN: CHASSIS DIMENSIONS						EMPTY (mm)	LOADED (mm)	EMPTY (mm)	LOADED (mm)	WIDTH (mm)	
WHEELBASE	FOH	ROH	OAL	CA	CF	AE	H1	H2	H3	H4	W1	W2
4,250mm	1,450	2,325	8,107	3,310	5,635	940	3,210	3,138	1,159	1,129	2,240	2,500

Note: Chassis weight includes oil, water, AdBlue, 90% fuel and 90kg driver. Weight can vary ± 3%.

