



# TGM 15.250-290 4x4 BL CH – MINING



## CABS

	CC: NARROW, SHORT, NORMAL HEIGHT)	TN: NARROW, LONG, NORMAL HEIGHT	DN: NARROW, EXTRA LONG, NORMAL HEIGHT
EXTERNAL LENGTH	1,620mm	2,280mm	2,790mm
EXTERNAL WIDTH	2,240mm	2,240mm	2,240mm
INTERIOR LENGTH	1,550mm	2,145mm	2,650mm
INTERIOR WIDTH	2,070mm	2,070mm	2,070mm
ENGINE TUNNEL HEIGHT	260/140mm <sup>1</sup>	260mm	260mm
STANDING HEIGHT ON THE ENGINE TUNNEL	1,280mm	1,410mm	1,385mm
SEATS QUANTITY	2 (option for 3)	2	6 (option for 7)
STANDING HEIGHT IN FRONT OF THE CO-DRIVER'S SEAT	1,585mm	1,690mm	1,645/ 1,620mm
BUNK QUANTITY	-	1	N/A
BUNK WIDTH	-	800mm	N/A
BUNK LENGTH	-	1,960mm	N/A



## CAB EXTERIOR

	CC	TN	DN
CAB PAINT RAL 9016	✓	✓	✓
BUMPER PAINT – TEXTURED COATING	✓	✓	✓
CABIN TILT MECHANISM – MANUAL	✓	✓	✓
STEEL BUMPER	✓	✓	✓
WIDE/FINE MESH HEADLIGHT PROTECTORS	✓	✓	✓
TILTING ROOF MECHANICAL	✓	✓	✓
SUNVISOR	✓	✓	✓
CENTRAL LOCKING WITH REMOTE CONTROL	✓	✓	✓
WIPER ACTIVATION, MANUAL	✓	✓	✓
FRONT HEADLIGHTS, H7	✓	✓	✓
DAYTIME DRIVING LIGHTS, LED	✓	✓	✓
DRIVING LIGHT CONTROL, MANUAL	✓	✓	✓
COMPRESSED AIR HORNS	✓	✓	✓
EXTERIOR REAR VIEW MIRROR, ELECTRIC, MAIN AND SPOTTER	✓	✓	✓
KERB MIRROR LEFT, ELECTRIC	✓	✓	✓
FRONT MIRROR, MECHANICAL	✓	✓	✓

# TGM 15.250-290 4×4 BL CH – MINING



## CAB INTERIOR

	CC	TN	DN
MULTI-FUNCTION STEERING WHEEL, ADJUSTABLE HEIGHT AND ANGLE	✓	✓	✓
STEERING WHEEL, WITH PARKING POSITION	✓	✓	✓
COMFORT DRIVER'S SEAT, AIR-SPRUNG, WITH LUMBAR SUPPORT AND SHOULDER ADJUSTMENT	✓	✓	✓
DRIVER'S SEAT HEATING	✓	✓	✓
DRIVER'S SEAT ARM RESTS	✓	✓	✓
COMFORT CO-DRIVER'S SEAT, AIR-SPRUNG, WITH LUMBAR SUPPORT AND SHOULDER ADJUSTMENT	✓	✓	✓
CO-DRIVER'S SEAT ARM RESTS	✓	✓	✓
REAR BENCH SEAT FOR 4 PERSONS	-	-	✓
AIR-CONDITIONING SYSTEM, CLIMATRONIC	✓	✓	✓
INSTRUMENTATION, BASIC	✓	✓	✓
MMT INFOTAINMENT SYSTEM, ADVANCED BASIC	✓	✓	✓
MAN SOUND SYSTEM	✓	✓	✓
SMARTPHONE INTEGRATION	✓	✓	✓
PREPARATION FOR REAR-VIEW CAMERA, 2 UNITS, ONE CAMERA LINKED TO REVERSE GEAR	✓	✓	✓
EXTENSION FOR PREPARATION FOR REAR-VIEW CAMERA, CONNECTION BEHIND CAB	✓	✓	✓
ADJUSTABLE BUNK HEADSECTION	-	✓	-
110mm COLD FOAM MATTRESS	-	✓	-
UNDERBUNK COOLBOX	-	✓	-

CC Cab

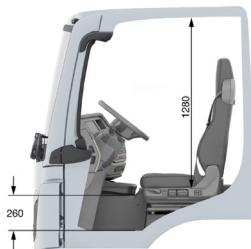

TN Cab

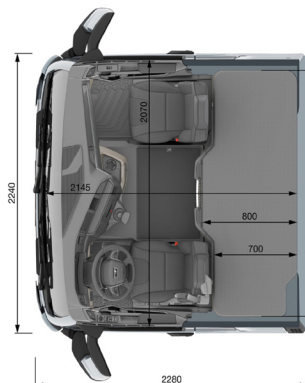
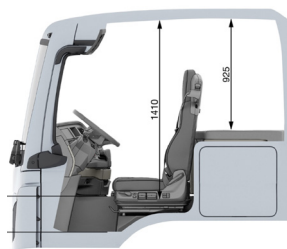

DN Cab

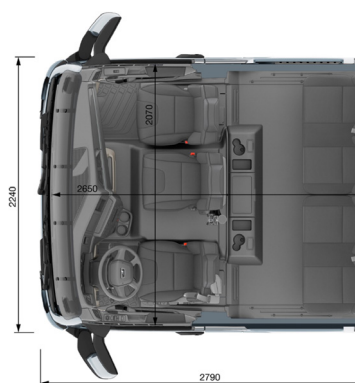
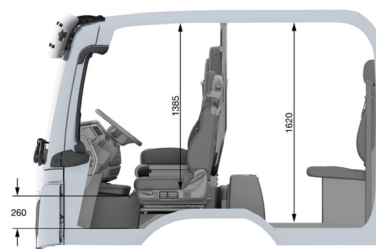

# TGM 15.250-290 4×4 BL CH – MINING



## ENGINE

	250hp / 184kW – MAN D0836 LFL86	290hp / 213kW – MAN D0836 LFL87
NOMINAL OUTPUT	184kW (250hp) at 2,200rpm	213kW (290hp) at 2,200rpm
MAX TORQUE	1,050Nm at 1,200–1,600rpm	1,150Nm at 1,200–1,700rpm
CYLINDERS & ENGINE TYPE	Six-cylinder in-line engine	Six-cylinder in-line engine
CAPACITY	6.9L	6.9L
EMISSION NORM	Euro 5	Euro 5
EMISSION CONTROL SYSTEM	SCR technology – without EGR	SCR technology – without EGR
ENGINE TURBO CHARGING	Single-stage turbo charger with direct air-air charge-air cooling	Single-stage turbo charger with direct air-air charge-air cooling
FUEL INJECTION	Electronically controlled common rail injection system	Electronically controlled common rail injection system



## INTAKE/EXHAUST SYSTEM

	CC	TN	DN
AIR INTAKE LHS CABIN NO REAR PROTRUSION	-	✓	-
AIR INTAKE REAR OF CABIN RHS WITH REAR PROTURUSION	✓	-	✓
EXHAUST SILENCER RIGHT SIDE	✓	✓	✓
EXHAUST SILENCER COVER	✓	✓	✓



## FRAME

	CC	TN	DN
FRAME PROFILE 220mm × 70mm × 7mm	✓	✓	✓
FINAL CROSS MEMBER, WITH HOLE PATTERN 120 × 55mm	✓	✓	✓
SPARE WHEEL HOIST ON LEFT SIDE, IN FRONT OF REAR AXLE	✓	✓	✓

# TGM 15.250-290 4×4 BL CH – MINING



## BRAKE SYSTEM

	CC	TN	DN
ANTI-LOCK BRAKING SYSTEM (ABS), OFFROAD, WITH ADDITIONAL OFF-ROAD LOGIC	✓	✓	✓
MAN EASY START	✓	✓	✓
MAN HIGH PERFORMANCE ENGINE BRAKE	✓	✓	✓
ELECTRONIC BRAKING SYSTEM	✓	✓	✓
1 CYLINDER AIR COMPRESSOR 352 CCM	✓	✓	✓
PARK BRAKE CONTROL, FLOOR MOUNTED	✓	✓	✓



## DRIVETRAIN & CHASSIS EQUIPMENT

	CC	TN	DN
MAN TIPMATIC 1212 OD AMT GEARBOX	✓	✓	✓
MAN IDLE SPEED DRIVING GEARBOX FUNCTION	✓	✓	✓
MAN TIPMATIC OFFROAD GEARBOX SHIFT STRATEGY	✓	✓	✓
SINGLE-DISC CLUTCH, 395 MM, DRY	✓	✓	✓
TRANSFER CASE MAN G102 WITH ON-ROAD AND OFF-ROAD GEAR	✓	✓	✓
TRANSFER CASE LOCK MANAGEMENT, ELECTRONIC (VSM)	✓	✓	✓
FRONT AXLE TYPE, PERMANENT	✓	✓	✓
6.3t STRAIGHT FRONT PLANETARY AXLE	✓	✓	✓
6.3t 2 LEAF PARABOLIC FRONT SUSPENSION	✓	✓	✓
9.5t STRAIGHT REAR PLANETARY AXLE	✓	✓	✓
9.2t 4 BAG ECAS REAR CONSTRUCTION SUSPENSION	✓	✓	✓
5.07 REAR AXLE RATIO	✓	✓	✓
GY OMNITRAC MSS 11R R22.5" FRONT TYRES	✓	✓	✓
GY OMNITRAC MSS 11R R22.5" REAR TYRES	✓	✓	✓
1 × 300L STEEL FUELTANK MOUNTED RHS CHASSIS	✓	✓	✓
35L ADBLUE TANK MOUNTED RHS CHASSIS	✓	✓	-
27L ADBLUE TANK MOUNTED RHS CHASSIS	-	-	✓

# TGM 15.250-290 4×4 BL CH – MINING



## ELECTRICAL SYSTEM

	CC	TN	DN
BATTERY, 12V, 88AH, 2 UNITS, MAINTENANCE FREE	✓	-	✓
BATTERY, 12 V, 175 AH, 2 UNITS, MAINTENANCE FREE	-	✓	-
THREE-PHASE ALTERNATOR 28V, 120A, 3,360W, LONGLIFE ECO	-	✓	-
MAIN BATTERY SWITCH, MECHANICAL	✓	✓	✓
LOCKABLE BATTERY BOX, WITHOUT PADLOCK	✓	✓	✓
SAFETY CUT-OUT	✓	✓	✓



## SAFETY FEATURES

	CC	TN	DN
ROAD SPEED LIMITER, ADJUSTABLE, LIMITER (ENGINE SPEED REGULATION)	✓	✓	✓
EMERGENCY BRAKING SIGNAL	✓	✓	✓
CRUISE CONTROL	✓	✓	✓



## GVM & GCM

	CC	TN	DN
GROSS VEHICLE MASS (GVM)	15,000kg	15,000kg	15,000kg
GROSS COMBINATION MASS (GCM)	28,000kg	28,000kg	28,000kg
GROSS COMBINATION MASS (GCM) *OPTIONAL, RESTRICTIONS APPLY	20,000kg	20,000kg	20,000kg



## FACTORY WARRANTY

	CC	TN	DN
1 YEAR ENTIRE VEHICLE COVERAGE	✓	✓	✓
2 YEAR DRIVE LINE COVERAGE	✓	✓	✓

# TGM 15.250-290 4x4 BL CH – MINING



## CHASSIS DIMENSIONS AND WEIGHTS

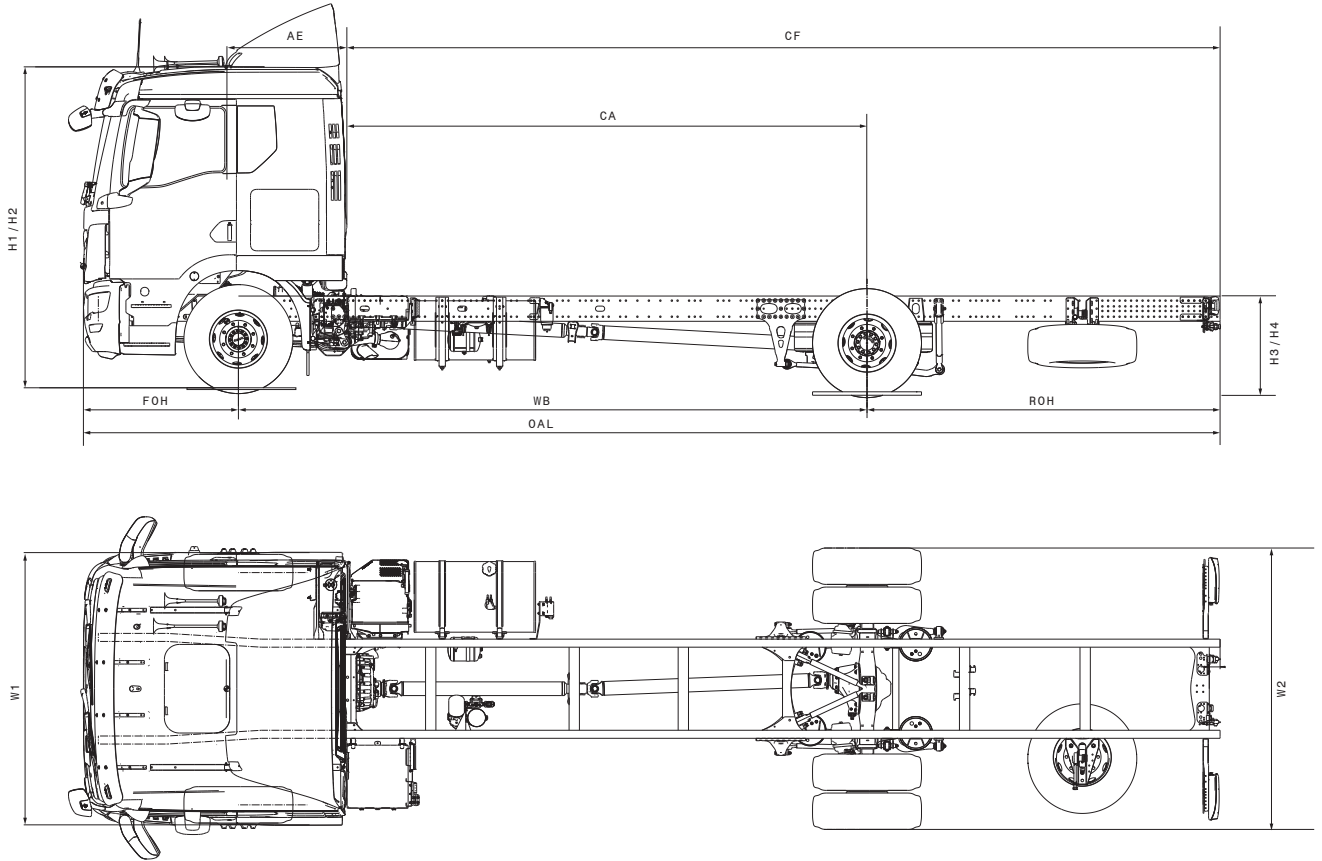

# TGM 15.250-290 4×4 BL CH – MINING



## CHASSIS DIMENSIONS AND WEIGHTS

WHEELBASE	CC CAB: WEIGHTS			TN CAB: WEIGHTS			DN CAB: WEIGHTS			TURNING	
	Front kg	Rear kg	Total	Front kg	Rear kg	Total	Front kg	Rear kg	Total	Kerb to Kerb	Wall to Wall
3,650mm*	4,023	1,838	5,861	4,267	1,882	6,149	4,264	1,843	6,107	14.4	15.8
3,950mm	4,047	1,844	5,891	4,294	1,885	6,179	4,340	1,952	6,292	15.4	16.8
4,250mm	4,069	1,852	5,921	4,319	1,890	6,209	4,369	1,953	6,322	16.4	17.8

\* reduction in fuel capacity required for DN Cabin

WHEELBASE	CC CABIN: CHASSIS DIMENSIONS						MAX (mm)	EMPTY (mm)	LOADED (mm)	EMPTY (mm)	LOADED (mm)		
	FOH	ROH	OAL	CA	CF	AE	BL	H1	H2	H3	H4	W1	W2
3,650mm	1,532	2,125	7,307	3,209	5,334	441	5,399	3,113	3,034	1,142	1,112	2,240	2,500
3,950mm	1,532	2,125	7,607	3,509	5,634	441	5,879	3,113	3,034	1,142	1,112	2,240	2,500
4,250mm	1,532	2,325	8,107	3,809	6,134	441	6,359	3,113	3,034	1,142	1,112	2,240	2,500

WHEELBASE	TN CABIN: CHASSIS DIMENSIONS						MAX (mm)	EMPTY (mm)	LOADED (mm)	EMPTY (mm)	LOADED (mm)		
	FOH	ROH	OAL	CA	CF	AE	BL	H1	H2	H3	H4	W1	W2
3,650mm	1,532	2,125	7,307	2,710	4,835	940	4,900	3,193	3,121	1,142	1,112	2,240	2,500
3,950mm	1,532	2,125	7,607	3,010	5,135	940	5,380	3,193	3,121	1,142	1,112	2,240	2,500
4,250mm	1,532	2,325	8,107	3,310	5,635	940	5,860	3,193	3,121	1,142	1,112	2,240	2,500

WHEELBASE	DN CABIN: CHASSIS DIMENSIONS						MAX (mm)	EMPTY (mm)	LOADED (mm)	EMPTY (mm)	LOADED (mm)		
	FOH	ROH	OAL	CA	CF	AE	BL	H1	H2	H3	H4	W1	W2
3,650mm	1,532	2,125	7,307	2,096	4,221	1,554	4,286	3,191	3,121	1,142	1,112	2,240	2,500
3,950mm	1,532	2,125	7,607	2,396	4,521	1,554	4,766	3,191	3,121	1,142	1,112	2,240	2,500
4,250mm	1,532	2,325	8,107	2,696	5,021	1,554	5,246	3,191	3,121	1,142	1,112	2,240	2,500

Note: Chassis weight includes oil, water, AdBlue, 90% fuel and 90kg driver. Weight can vary  $\pm$  3%.