



TGS 26.360-440 6×4 BL SA



CABS

	NN: NARROW, SHORT, NORMAL HEIGHT	TN: NARROW, LONG, NORMAL HEIGHT
EXTERNAL LENGTH	1,880mm	2,280mm
EXTERNAL WIDTH	2,240mm	2,240mm
INTERIOR LENGTH	1,770mm	2,145mm
INTERIOR WIDTH	2,070mm	2,070mm
ENGINE TUNNEL HEIGHT	280mm	260mm
STANDING HEIGHT ON THE ENGINE TUNNEL	1,410mm	1,410mm
SEATS QUANTITY	2 (optional for 3)	2
STANDING HEIGHT IN FRONT OF THE CO-DRIVER'S SEAT	1,645mm	1,690mm
BUNK QUANTITY	-	1
BUNK WIDTH	-	800mm
BUNK LENGTH	-	1,960mm



CAB EXTERIOR

	NN	TN
CAB PAINT RAL 9016 - TRAFFIC WHITE	✓	✓
BUMPER PAINT RAL 9016 - TRAFFIC WHITE	✓	✓
CABIN TILT MECHANISM - ELECTRIC	✓	✓
ROOF SPOILER	✓	✓
TILTING ROOF MECHANICAL	✓	-
GLASS ROOF HATCH ELECTRIC	-	✓
SUNVISOR	✓	✓
CENTRAL LOCKING WITH REMOTE CONTROL	✓	✓
WIPER ACTIVATION, MANUAL	✓	✓
FRONT HEADLIGHTS, H7	✓	✓
DAYTIME DRIVING LIGHTS, LED	✓	✓
DRIVING LIGHT CONTROL, MANUAL	✓	✓
COMPRESSED AIR HORNS	✓	✓
EXTERIOR REAR VIEW MIRROR, ELECTRIC, MAIN AND SPOTTER	✓	✓
KERB MIRROR LEFT, ELECTRIC	✓	✓
FRONT MIRROR, MECHANICAL	✓	✓

TGS 26.360-440 6×4 BL SA



CAB INTERIOR

	NN	TN
MULTI-FUNCTION STEERING WHEEL, ADJUSTABLE HEIGHT AND ANGLE	✓	✓
STEERING WHEEL, WITH PARKING POSITION	✓	✓
STEERING LOCK, WITH ELECTRONIC IMMOBILISER	✓	✓
COMFORT DRIVER'S SEAT, AIR-SPRUNG, WITH LUMBAR SUPPORT AND SHOULDER ADJUSTMENT	✓	✓
DRIVER'S SEAT HEATING	✓	✓
DRIVER'S SEAT ARM RESTS	✓	✓
VARIO CO-DRIVER'S SEAT, DOES NOT ROTATE, STATIC	✓	✓
CO-DRIVER'S SEAT ARM RESTS	✓	✓
AIR-CONDITIONING SYSTEM, MANUAL	✓	✓
INSTRUMENTATION, BASIC	✓	✓
MMT INFOTAINMENT SYSTEM, ADVANCED MID	✓	✓
MAN SOUND SYSTEM	✓	✓
SMARTPHONE INTEGRATION	✓	✓
AUSTRALIA NAVIGATION MAP	✓	✓
PREPARATION FOR REAR-VIEW CAMERA, 2 UNITS, ONE CAMERA LINKED TO REVERSE GEAR	✓	✓
ADJUSTABLE BUNK HEADSECTION	-	✓
110mm COLD FOAM MATTRESS	-	✓
UNDERBUNK COOLBOX	-	✓

NN Cab

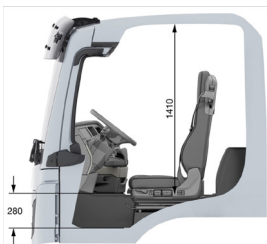

TN Cab

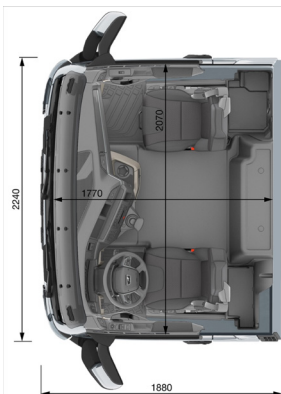
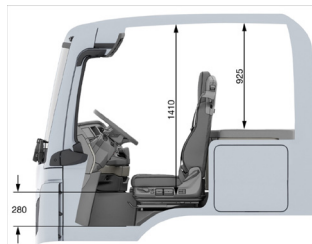

TGS 26.360-440 6×4 BL SA



ENGINES

	360hp / 265kW – MAN D2066 LF59	400hp / 294kW – MAN D2066 LF58	440hp / 324kW – MAN D2066 LF57
NOMINAL OUTPUT	265kW (360hp) at 1,900rpm	294kW (400hp) at 1,900rpm	324kW (440hp) at 1,900rpm
MAX TORQUE	1,800Nm at 1,000–1,400rpm	1,900Nm at 1,000–1,400rpm	2,100Nm at 1,000–1,400rpm
CYLINDERS & ENGINE TYPE	Six-cylinder in-line engine	Six-cylinder in-line engine	Six-cylinder in-line engine
CAPACITY	10.5L	10.5L	10.5L
EMISSION NORM	Euro 5	Euro 5	Euro 5
EMISSION CONTROL SYSTEM	SCR exhaust gas aftertreatment – without EGR	SCR exhaust gas aftertreatment – without EGR	SCR exhaust gas aftertreatment – without EGR
ENGINE TURBO CHARGING	Turbocharger, with intercooling	Turbocharger, with intercooling	Turbocharger, with intercooling
FUEL INJECTION	Electronically controlled common rail injection system	Electronically controlled common rail injection system	Electronically controlled common rail injection system



INTAKE/EXHAUST SYSTEM

	NN	TN
AIR INTAKE LHS CABIN NO REAR PROTRUSION	✓	✓
EXHAUST SILENCER LEFT SIDE	✓	✓
EXHAUST OUTLET, BOTTOM	✓	✓
PRE-SEPARATOR FOR ENGINE AIR INTAKE	✓	✓



FRAME

	NN	TN
FRAME PROFILE 270mm × 85mm × 8mm	✓	✓
FRONT UNDERRIDE PROTECTION	✓	✓
FINAL CROSS MEMBER WITH HOLE PATTERN 160mm × 100mm	✓	✓

TGS 26.360-440 6×4 BL SA



BRAKE SYSTEM

	NN	TN
ANTI-LOCK BRAKING SYSTEM	✓	✓
ELECTRONIC STABILITY PROGRAM	✓	✓
ANTI-SLIP CONTROL	✓	✓
MAN EASY START	✓	✓
MAN EVBEC HIGH PERFORMANCE ENGINE BRAKE	✓	✓
ELECTRONIC BRAKING SYSTEM	✓	✓
1 CYLINDER AIR COMPRESSOR 360 CCM	✓	✓
PARK BRAKE CONTROL, FLOOR MOUNTED	✓	✓
ANTI JACKKNIFE BRAKE, FLOOR MOUNTED	✓	✓



DRIVETRAIN & CHASSIS EQUIPMENT

	NN	TN
MAN TIPMATIC 12 28 OD AMT GEARBOX	✓	✓
MAN EFFICIENTROLL GEARBOX FUNCTION	✓	✓
MAN TIPMATIC EFFICIENCY DRIVING PROGRAM	✓	✓
MAN IDLE SPEED DRIVING GEARBOX FUNCTION	✓	✓
SINGLE-DISC CLUTCH, 395mm, DRY	✓	✓
9.5t DROPPED FRONT AXLE	✓	✓
8t 2 LEAF PARABOLIC FRONT SUSPENSION	✓	✓
TANDEM 13t HYPOID REAR AXLES	✓	✓
TANDEM 11.5t 4 BAG ECAS REAR SUSPENSION	✓	✓
4.11 REAR AXLE RATIO	✓	✓
PI FR:01 295/80R22.5" FRONT TYRES	✓	✓
PI TR:01 295/80R22.5" REAR TYRES	✓	✓
1 × 590L ALLOY FUELTANK MOUNTED RHS CHASSIS	✓	✓
35L ADBLUE TANK MOUNTED LHS CHASSIS	✓	✓

TGS 26.360-440 6×4 BL SA



ELECTRICAL SYSTEM

	NN	TN
BATTERY, 12 V, 175 AH, 2 UNITS, MAINTENANCE FREE	✓	✓
ALTERNATOR, BASIC	✓	-
THREE-PHASE ALTERNATOR 28 V, 120 A, 3,360W, LONGLIFE ECO	-	✓
MAIN BATTERY SWITCH, MECHANICAL	✓	✓
SAFETY CUT-OUT	✓	✓



SAFETY FEATURES

	NN	TN
LANE GUARD SYSTEM (LGS)	✓	✓
ADVANCED EMERGENCY BRAKE ASSIST (EBA)	✓	✓
ROAD SPEED LIMITER, ADJUSTABLE, LIMITER (ENGINE SPEED REGULATION)	✓	✓
EMERGENCY BRAKING SIGNAL (ESS)	✓	✓
ADAPTIVE CRUISE CONTROL (ACC)	✓	✓
DRIVER'S AIRBAG WITH SEATBELT PRE TENSIONER	✓	✓



GVM & GCM

	NN	TN
GROSS VEHICLE MASS (GVM)	26,000kg	26,000kg
GROSS COMBINATION MASS (GCM)	68,000kg	68,000kg



FACTORY WARRANTY

	NN	TN
1 YEAR ENTIRE VEHICLE COVERAGE	✓	✓
5 YEAR / 500,000km DRIVELINE COVERAGE	✓	✓

TGS 26.360-440 6×4 BL SA



CHASSIS DIMENSIONS AND WEIGHTS

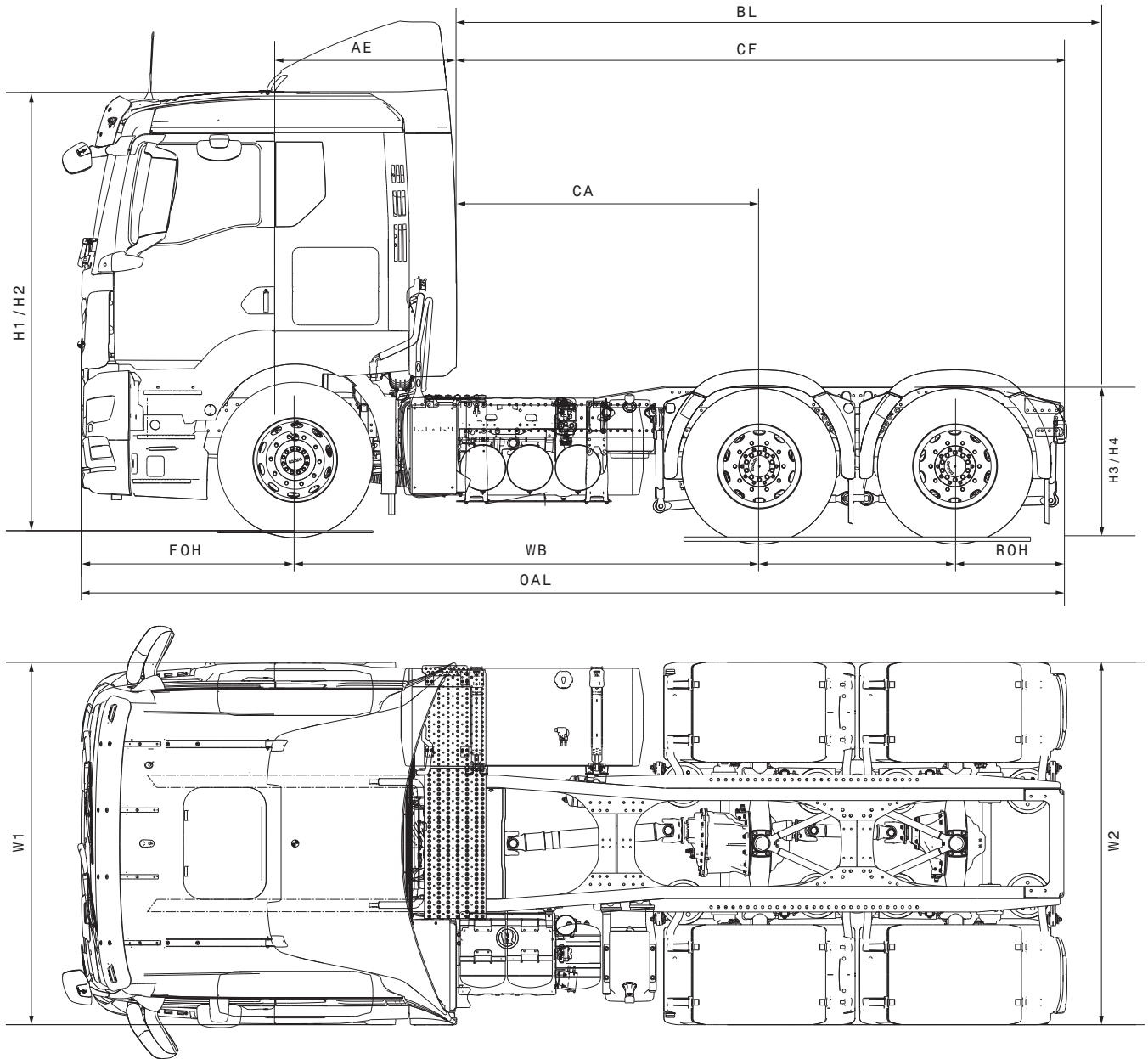

TGS 26.360-440 6×4 BL SA



CHASSIS DIMENSIONS AND WEIGHTS

WHEELBASE	NN CAB: WEIGHTS			TN CAB: WEIGHTS			TURNING	
	Front kg	Rear kg	Total	Front kg	Rear kg	Total	Kerb to Kerb	Wall to Wall
3,200mm	4,828	3,460	8,288	4,998	3,476	8,474	16.2	17.7

WHEELBASE	NN CABIN: CHASSIS DIMENSIONS						MAX (mm)	EMPTY (mm)	LOADED (mm)	EMPTY (mm)	LOADED (mm)		
	FOH	ROH	OAL	CA	CF	AE	BL	H1	H2	H3	H4	W1	W2
3,200mm	1,475	725	6,907	2,735	4,810	465	N/A	3,657	3,593	998	968	2,500	2,240

WHEELBASE	TN CABIN: CHASSIS DIMENSIONS						MAX (mm)	EMPTY (mm)	LOADED (mm)	EMPTY (mm)	LOADED (mm)		
	FOH	ROH	OAL	CA	CF	AE	BL	H1	H2	H3	H4	W1	W2
3,200mm	1,475	725	6,907	2,735	4,810	465	N/A	3,657	3,593	998	968	2,500	2,240

Note: Chassis weight includes oil, water, AdBlue, 90% fuel and 90kg driver. Weight can vary ± 3%.