



TGX 26.510 6×4 BL SA



CABS

	GM: WIDE, LONG, MEDIUM HEIGHT
EXTERNAL LENGTH	2,280mm
EXTERNAL WIDTH	2,440mm
INTERIOR LENGTH	2,145mm
INTERIOR WIDTH	2,270mm
ENGINE TUNNEL HEIGHT	120mm
STANDING HEIGHT ON THE ENGINE TUNNEL	1,860mm
SEATS QUANTITY	2
STANDING HEIGHT IN FRONT OF THE CO-DRIVER'S SEAT	1,940mm
BUNK QUANTITY	1 (option for 2)
BUNK WIDTH	800mm
BUNK LENGTH	2,000mm



CAB EXTERIOR

	GM
CAB PAINT RAL 9016 - TRAFFIC WHITE	✓
BUMPER PAINT - RAL 9016 - TRAFFIC WHITE	✓
CABIN TILT MECHANISM - ELECTRIC	✓
ROOF SPOILER	✓
GLASS ROOF HATCH, ELECTRIC	✓
SUNVISOR	✓
CENTRAL LOCKING WITH REMOTE CONTROL	✓
WIPER ACTIVATION, AUTOMATIC, WITH RAIN SENSOR (AUTOMATIC WIPERS)	✓
FRONT HEADLIGHTS, LED	✓
DAYTIME DRIVING LIGHTS, LED	✓
FOG LIGHTS, LED	✓
CORNERING LIGHT, LED	✓
DRIVING-LIGHT CONTROL, AUTOMATIC, WITH LIGHT SENSOR	✓
COMPRESSED AIR HORNS	✓
EXTERIOR REAR VIEW MIRROR, ELECTRIC, MAIN AND SPOTTER	✓
KERB MIRROR LEFT, ELECTRIC	✓
FRONT MIRROR, MECHANICAL	✓

TGX 26.510 6×4 BL SA



CAB INTERIOR

	GM
MULTI-FUNCTION STEERING WHEEL, ADJUSTABLE HEIGHT AND ANGLE	✓
STEERING WHEEL, WITH PARKING POSITION	✓
STEERING LOCK, WITH ELECTRONIC IMMOBILISER	✓
COMFORT DRIVER'S SEAT, AIR-SPRUNG, WITH LUMBAR SUPPORT AND SHOULDER ADJUSTMENT	✓
DRIVER'S SEAT HEATING	✓
DRIVER'S SEAT ARM RESTS	✓
VARIO CO-DRIVER'S SEAT, ROTATES, FOLD UP	✓
CO-DRIVER'S SEAT ARM RESTS	✓
AIR-CONDITIONING SYSTEM, CLIMATRONIC	✓
AIR-CONDITIONING SYSTEM, MANUAL	-
PROFESSIONAL INSTRUMENTATION, 12.3"	✓
MAN NAVIGATION PROFESSIONAL MEDIA SYSTEM, 12.3"	✓
ADVANCED MID INSTRUMENTATION	-
MAN Navigation Basic 7"	-
MAN SOUND SYSTEM	✓
SMARTPHONE INTEGRATION	✓
AUSTRALIA NAVIGATION MAP	✓
PREPARATION FOR REAR-VIEW CAMERA, 2 UNITS, ONE CAMERA LINKED TO REVERSE GEAR	✓
ADJUSTABLE BUNK HEADSECTION	✓
160mm COLD FOAM MATTRESS	✓
UNDERBUNK COOLBOX	✓

GM Cab

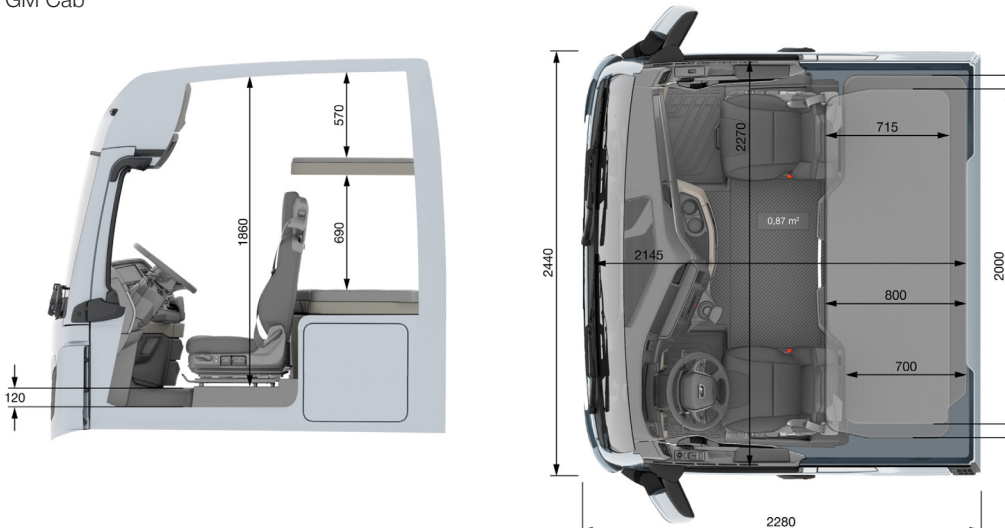

TGX 26.510 6×4 BL SA



ENGINES

	470hp/346kW - MAN D2676 LFAI	510hp/375kW - MAN D2676 LF78
NOMINAL OUTPUT	346kW (470hp) at 1,800rpm	375kW (510hp) at 1,900rpm
MAX TORQUE	2,400Nm at 930–1,350rpm	2,600Nm at 1,050–1,350rpm
CYLINDERS & ENGINE TYPE	Six-cylinder in-line engine	Six-cylinder in-line engine
CAPACITY	12.4L	12.4L
EMISSION NORM	Euro 6	Euro 6
EMISSION CONTROL SYSTEM	SCR/Soft EGR/CRT	SCR/Soft EGR/CRT
ENGINE TURBO CHARGING	Turbocharger, with intercooling	Turbocharger, with intercooling
FUEL INJECTION	Electronically controlled common rail injection system	Electronically controlled common rail injection system



INTAKE/EXHAUST SYSTEM

	GM
AIR INTAKE LHS CABIN NO REAR PROTRUSION	✓
EXHAUST SILENCER RIGHT SIDE	✓
EXHAUST OUTLET, VERTICAL	✓
PRE-SEPARATOR FOR ENGINE AIR INTAKE	✓



FRAME

	GM
FRAME PROFILE 270mm × 85mm × 8mm	✓
FRONT UNDERRIDE PROTECTION	✓
FINAL CROSS MEMBER WITH HOLE PATTERN 160 × 100mm	✓



TGX 26.510 6×4 BL SA



BRAKE SYSTEM

	GM
ANTI-LOCK BRAKING SYSTEM	✓
ELECTRONIC STABILITY PROGRAM	✓
ANTI-SLIP CONTROL	✓
MAN EASY START	✓
MAN EVBEC HIGH PERFORMANCE ENGINE BRAKE	✓
ELECTRONIC BRAKING SYSTEM	✓
1 CYLINDER AIR COMPRESSOR 360 CCM	✓
PARK BRAKE CONTROL, FLOOR MOUNTED	✓
AMTI JACKNIFE BRAKE, FLOOR MOUNTED	✓



DRIVETRAIN & CHASSIS EQUIPMENT

	GM
MAN TIPMATIC 12 28 OD AMT GEARBOX	✓
MAN EFFICIENTROLL GEARBOX FUNCTION	✓
MAN TIPMATIC EFFICIENCY DRIVING PROGRAM	✓
MAN IDLE SPEED DRIVING GEARBOX FUNCTION	✓
SINGLE-DISC CLUTCH, 430mm, DRY	✓
9.2t DROPPED FRONT AXLE	✓
9.5t 3 LEAF PARABOLIC FRONT SUSPENSION	✓
13t HYPOID REAR AXLES	✓
11.5t 4 BAG ECAS REAR SUSPENSION	✓
3.7 REAR AXLE RATIO	✓
PI FR:01 295/80R22.5" FRONT TYRES	✓
PI TR:01 295/80R22.5" REAR TYRES	✓
1 × 620L FUEL /85L ADBLUE ALLOY COMBI TANK LEFT	✓
1 × 460L ALLOY FUELTANK RIGHT	✓
ALCOA-DURA BRIGHT ALLOY WHEELS	✓

TGX 26.510 6×4 BL SA



ELECTRICAL SYSTEM

	GM
2 BATTERIES, 12V, 175AH, STANDARD (SLI), MAINTENANCE FREE	✓
THREE-PHASE ALTERNATOR 28V, 120A, 3,360W, LONGLIFE ECO	✓
MAIN BATTERY SWITCH, MECHANICAL	✓
SAFETY CUT-OUT	✓



SAFETY FEATURES

	GM
LANE GUARD SYSTEM (LGA)	✓
COMFORT STEERING	✓
ADVANCED EMERGENCY BRAKE ASSIST (EBA)	✓
ROAD SPEED LIMITER, ADJUSTABLE, LIMITER (ENGINE SPEED REGULATION)	✓
EMERGENCY BRAKING SIGNAL (ESS)	✓
ADAPTIVE CRUISE CONTROL (ACC)	✓
DRIVER'S AIRBAG WITH SEATBELT PRE TENSIONER	✓



GVM & GCM

	GM
GROSS VEHICLE MASS (GVM)	26,000kg
GROSS COMBINATION MASS (GCM)	70,000kg
GROSS COMBINATION MASS (GCM) *OPTIONAL, RESTRICTIONS APPLY	90,000kg



FACTORY WARRANTY

	GM
1 YEAR ENTIRE VEHICLE COVERAGE	✓
5 YEAR 1,000,000KM DRIVELINE COVERAGE - UP TO 70T GCM	✓
4 YEAR / 800,000KM DRIVELINE COVERAGE - 70T TO 90T GCM	✓

TGX 26.510 6×4 BL SA



CHASSIS DIMENSIONS AND WEIGHTS

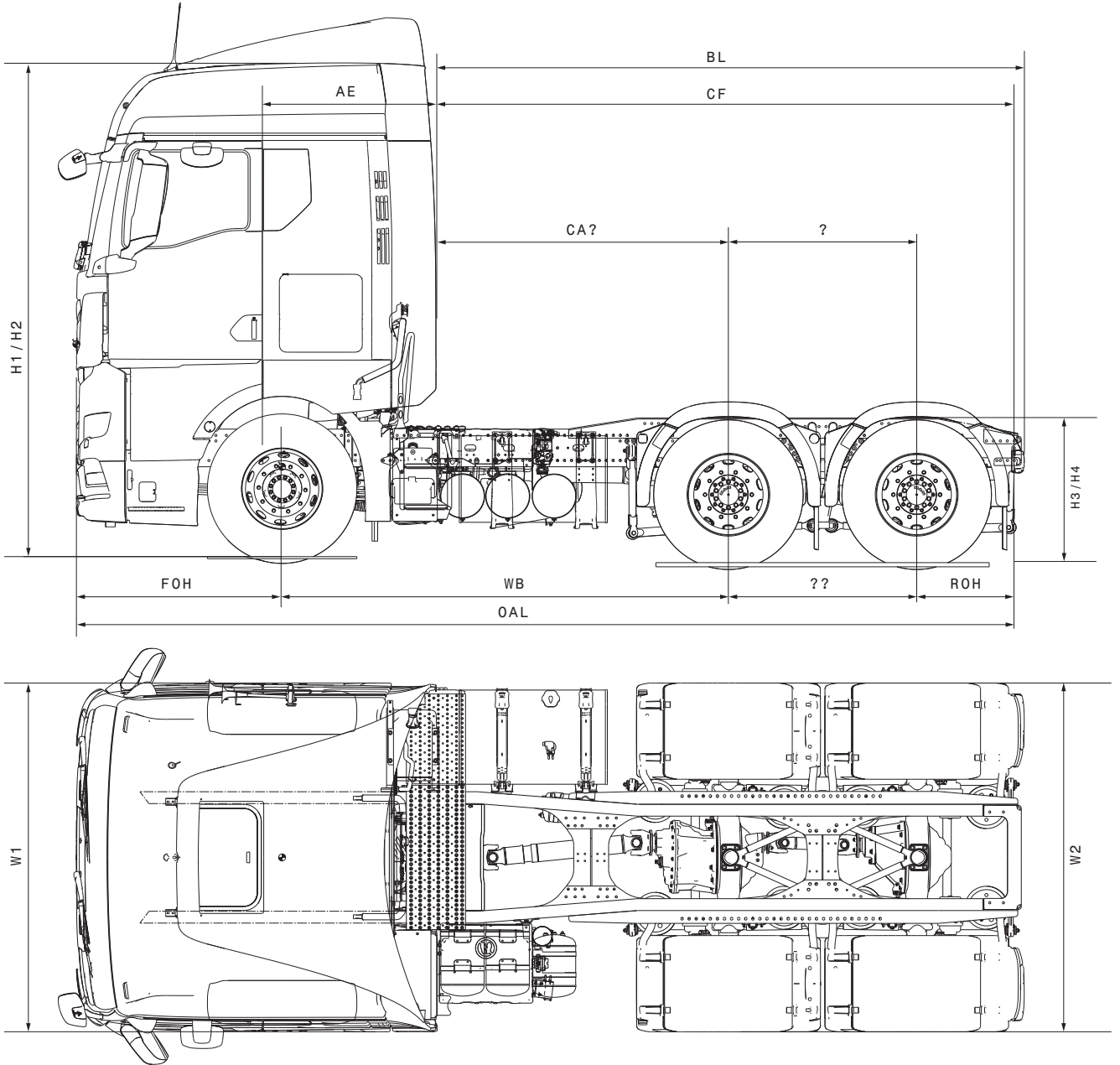

TGX 26.510 6×4 BL SA



CHASSIS DIMENSIONS AND WEIGHTS

WHEELBASE	GM CAB: WEIGHTS			TURNING	
	Front kg	Rear kg	Total	Kerb to Kerb	Wall to Wall
3,300mm	5,661	4,070	9,731	16.9	18.5

WHEELBASE	GM CABIN: CHASSIS DIMENSIONS						MAX (mm)	EMPTY (mm)	LOADED (mm)	EMPTY (mm)	LOADED (mm)		
	FOH	ROH	OAL	CA	CF	AE	BL	H1	H2	H3	H4	W1	W2
3,300mm	1,475	725	7,007	2,205	4,305	1,171	N/A	3,968	3,870	998	968	2,500	2,440

Note: Chassis weight includes oil, water, AdBlue, 90% fuel and 90kg driver. Weight can vary ± 3%.

